

# Design of Intelligent Construction System for Assembly Building Based on Improved IoT

Juan Wang

College of Civil Engineering, Zhengzhou University of Technology, Zhengzhou 450000, China

E-mail: eadgeoofdream2023@126.com

**Keywords:** IoT, assembly building, smart construction, genetic simulated annealing algorithm, synergy

**Received:** March 12, 2024

*Assembled construction can serve the purpose of saving resources, reducing costs and minimizing the impact on the environment. The construction process is essentially impossible without the support of advanced information technology. The study analyzes the functional requirements of an intelligent construction system for assembly buildings in four stages: design, production, transportation and installation based on the Internet of Things technology in order to realize the collaborative efforts of the stakeholders of assembly buildings. Additionally, by utilizing social network analysis and synergy theory, the study develops a dual-objective optimization model that thoroughly takes into account the synergistic influence between assembly construction services and service quality. The findings indicated that the system combines both efficiency and safety, and the genetic simulated annealing algorithm used to improve the Internet of Things assembly intelligent construction system has a service quality value of 4.52, a synergy value of 5.26, and an objective function value of 4.81, which are greater than that of the genetic algorithm and the simulated annealing algorithm. This intelligent construction system serves as a model for the development of intelligent construction systems for assembly buildings. It enables the realization of process data sharing, enabling data-driven business decision-making, increased productivity, and decreased management costs.*

*Povzetek: Raziskava se ukvarja z delovanjem pametnega konstrukcijskega sistema za montažne stavbe, ki temelji na tehnologiji interneta stvari (IoT).*

## 1 Introduction

To improve the level of production, operation, and management of the enterprise, the 14th Five-Year Plan for the development of the construction industry states that it is necessary to improve the level of informationization and intelligence. It also encourages construction enterprises to apply technologies like the Internet of Things (IoT), cloud computing, big data, artificial intelligence, and so on [1]. Currently, there is a certain foundation for the application of IoT technology in assembly building (AB), but it is still in its infancy in the field of smart construction (SC), which has not yet formed a complete sharing of information (SI) system [2-3]. AB has the advantages of high production efficiency, controllable quality, green environmental protection, short construction period and low cost, but at present there are still the following problems with AB in China: (1) The level of informatization is not high, and project construction information cannot be effectively integrated and managed and shared. (2) Insufficient synergy between industrial chains, significant obstacles between disparate information systems, and an inability to achieve the successful integration of data across the whole construction life cycle. (3) The problem of information silos is prominent, and information exchange and sharing in the construction process of construction

projects are difficult, making it difficult to play the role of informationization in the control of the whole life cycle of AB [4-5]. To address the above issues, the construction of SC system based on IoT technology using AB is studied to systematically integrate the stages of design, production, transportation, and installation in order to realize data-driven business decision-making, improve production efficiency, and reduce management costs.

The article develops the research through four parts, the first part is a review of the applications of IoT and the current state of research on SC systems for AB. The second part is the design of the SC system for AB. The performance validation of the study's suggested system makes up the final section. The end is covered in the fourth section.

## 2 Related works

AB construction is dispersed in multiple dimensions of operation space such as manufacturing of prefabricated components, logistics and transportation, and on-site assembly, which has been studied by many scholars in order to improve the construction efficiency. Yan et al. monitored and evaluated the assembly process from the perspective of schedule, with the goal of avoiding schedule delays. Moreover, they utilized computer vision to detect prefabricated components and workers remotely, and then used the weighted kernel density estimation

method to determine the progress status of assembly operations and other operations. Finally, the duration of the AB construction project was predicted based on the monitored schedule status, and the schedule was evaluated by striving for the schedule management method [6]. To show the data of AB intelligent construction, Ouyang and other researchers carried out case design and analysis based on P-ISOMAP algorithm and BIM technology. According to the findings, intelligent construction's information visualization satisfied public needs, and informatization helped with production and quality control while directing assembly [7]. Li and Huang used the prestressed AB structure as their study subject and the node reinforced wall as the point of entry to investigate the damage manner and energy dissipation properties of the structure under various ground vibration scenarios. The study indicated that the prestressed assembled structure with axial compression ratio of 0.3 and prestress less than 0.5 has the best seismic performance, which is in line with the seismic design code. At the same time, the system also showed good self-healing properties and better seismic response to different seismic waves [8]. Ding et al. developed a graduated intelligent manufacturing system in order to achieve stable, resilient, and applicable assembly production, real-time visibility and traceability of prefabricated production through IoT, and improved the performance level of scheduling and executing decisions under large fluctuations in runtime based on a multi-stage adaptive decision-making mechanism. The results showed that the method improved delayed artifact reduction by more than 70% compared to two traditional methods [9]. To investigate the efficacy of implementing low-carbon practices in the assembly construction process, Wang et al. created a system dynamics model using a game theoretic method. This addressed the issue of carbon emissions in the production process of prefabricated structures. The system dynamics model supported the low-carbon practices of AB supply chain participants. It also assisted the government in developing forward-looking carbon emission reduction policies. This was achieved by describing the equilibrium of the game model and reflecting the carbon emission sources during prefabricated component production, transportation, and on-site assembly [10].

IoT systems can improve project productivity and quality, shorten project duration, reduce cost overruns, decrease project management complexity, and enhance

site safety. Wu et al. designed a microgrid smart building scheme based on layered IoT in order to digitize and automate energy. To dynamically activate the real-time mutual reaction of generation and load, the study first built a two-dimensional fused hierarchical structure for microgrid and building composite load interaction. It then presented a state transition mechanism driven by a combination of time and events. To achieve autonomous supply and demand balancing, the study's conclusion suggested a power balance control algorithm powered by a self-consumption method [11]. To achieve intelligent detection of cracks in concrete structures, Babu and other scholars developed an IoT based detection system. With the use of ultrasonic sensors and GSM and GPS modules, this system was able to locate and identify structural cracks that are invisible to the human eye. By sending brief messages about the cracks, the devices can communicate with each other via the IoT [12]. Xi and other researchers constructed a cost control and cost prediction model for smart buildings based on the prediction algorithm of IoT in response to the chaotic and difficult-to-manage operation mode of traditional city systems. The study also combined the current characteristics of smart city construction and constructed an engineering cost program. The suggested smart city cost prediction methodology can lower project costs after verification, which is very important economically for building smart cities [13]. Using a machine learning model of natural language processing technology, Lin et al. automated SI in the construction sector by integrating a bidirectional encoder representation with a mobile chatbot into a question and response system based on building information modeling and IoT AI. The system was validated to have good information retrieval and proved to be an effective method for generating fast decisions [14]. An IoT slicing technique was created by Casado-Vara et al. in response to issues with a large number of terminals, sensible allocation of scarce resources, topology, and inhomogeneity of smart buildings. This method processed heterogeneous temperature data gathered by IoT networks in smart buildings and transformed it into isomorphic data by combining complex networks and clusters to lower algorithmic input mistakes and enhance the monitoring and control of smart buildings [15]. A summary of the relevant work sections is shown in Table 1.

Table 1: Related works table

Author	Time	Main point
Yan et al.	2023	The use of computer vision to remotely detect prefabricated components and workers reduces construction time.
Ouyang et al.	2022	The visualization of intelligent construction information of prefabricated buildings is realized, which provides convenience for production and quality management.
Li et al.	2021	When the axial compression ratio is 0.3 and the prestress is less than 0.5, the seismic performance of prestressed structures is the best, which conforms to

		the seismic design code.
Ding et al.	2023	IoT-based prefabrication reduces workpiece delays by more than 70%.
Wang et al.	2022	The game theory approach is adopted to support low carbon practices of members of the prefabricated building supply chain.
Wu et al.	2020	A microgrid intelligent building scheme based on hierarchical IoT is designed to achieve an independent supply and demand balance.
Babu et al.	2022	An IoT-based detection system has been developed to successfully detect cracks in buildings that are not visible to the naked eye, but with low accuracy.
Xi et al.	2021	The cost control and cost prediction model of intelligent building based on IoT has been built, and the project cost has been successfully reduced.
Lin et al.	2022	Based on building information modeling and IoT artificial intelligence, automated information sharing in the construction industry is realized.
Casado-Vara et al.	2020	Developed an IoT slicing technology that improves the monitoring and control of smart buildings.

In conclusion, despite several suggestions from researchers to boost AB construction management effectiveness, certain outcomes have been attained. However, the optimization scheme still needs to be improved, so by constructing a SC system based on improved IoT for AB, it is expected to construct an effective breakthrough of the current bottlenecks such as low communication efficiency and difficult collaboration.

### 3 Smart construction system design for assembly building

The study builds a SC system for AB by introducing intelligent algorithms to integrate the information of inventory, production process, and resource allocation of construction sites and assembled construction (AC) workshops into production planning, and builds the corresponding mathematical model using intelligent algorithms and combines it with IoT.

#### 3.1 Assembled construction service portfolio optimization problem

AC involves multi-dimensional workspace such as production, manufacturing, transportation, assembly, etc. of AB, and the scheduling and management of its construction resources (e.g., personnel, materials, equipment, etc.) has the characteristics of heterogeneous geography, heterogeneous synchronization, cross-organizational, and mutual constraints, which leads to the problems of over-budgeting, over-scheduling, and difficult coordination of the AB project, and seriously restricts its promotion and application in China [16]. In the component manufacturing stage, when enterprises build the AB intelligent construction system based on IoT technology, they often establish the quality control system for AB products to achieve the purpose of "lean production" [17]. Fig. 1 shows the operational mechanism of the prefabricated component production phase. In the context of IoT, sensors record the entire component production process, collect information about each step, and transmit it to the quality monitoring system of the prefabricated component. This system can be integrated with upstream design and construction.

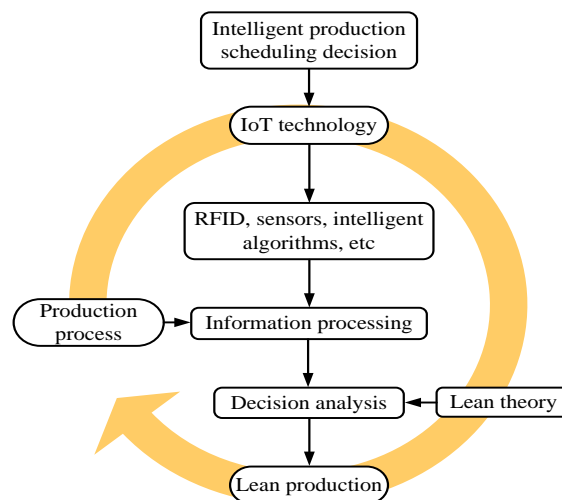

Figure 1: Operation mechanism of component production stage

The research is based on IoT and combines a variety of advanced information technologies to promote the construction of an SC system for AB. Through the SC system, multiple assembly construction services with different business granularity and functions can be realized [18]. Therefore, each functional module in the

assembly construction process can be combined to realize the whole process of assembly construction. In Fig. 2 the specific procedure for assembling construction service combinations is presented.

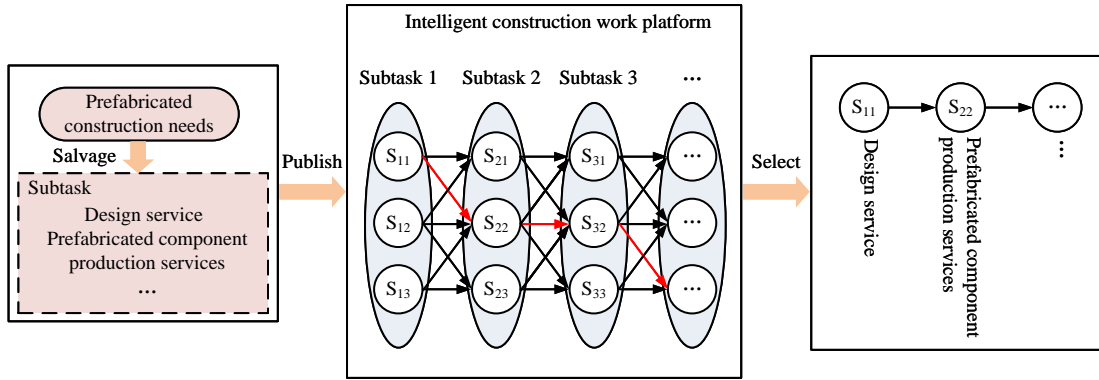

Figure 2: Intelligent construction service assembly program for prefabricated buildings

There are multiple synergistic relationships between AC services. Based on this, the study depicts the synergy between assembly construction services as a linear weighting of the strength of synergistic relationships in five different dimensions. Using the hierarchical analysis method, the synergistic relationships between firms are quantified, resulting in the quantitative expression of synergistic effects as shown in Equation (1).

$$SE(i, j) = \omega_1 SE_{TS} + \omega_2 SE_{IS} + \omega_3 SE_{PS} + \omega_4 SE_{Dis} + \omega_5 SE_{CR} \quad (1)$$

In Equation (1),  $SE(i, j)$  is the synergy effect between sequential AC services.  $SE_{PS}$ ,  $SE_{TS}$ ,  $SE_{Dis}$ ,  $SE_{IS}$  and  $SE_{CR}$  represent the evaluated values of the degree of synergy of process, technology, space, information and resources, respectively.  $\omega_i$  represents the weight coefficient of synergistic relationship, where  $\sum_{i=1}^5 \omega_i = 1, 0 \leq \omega_i \leq 1$ . The ratio of harmonized technical standards (TS) and the technical synergy of successive AC services are positively correlated. Therefore, technical synergy can be defined as the ratio, as indicated in Equation (2), between the number of harmonized TS contained in the consecutive AC services and the total number of TS.

$$SE_{TS}(i, j) = Tu_{ij} / (Te_i + Te_j) \quad (2)$$

In Equation (2),  $SE_{TS}(i, j)$  is the technical synergy and  $Tu_{ij}$  is the harmonized TS used between AB construction services.  $Te_i$  is the TS used by AC service  $i$  in the AC process.  $Te_j$  is the TS used by AC services  $j$  in the AC process. Enhancing SI among AC firms can improve the overall performance of the whole AC process. The study characterizes the SI capability between assembly construction services in terms of the frequency of information exchange, as shown in Equation (3).

$$SE_{IS}(i, j) = Tf_{ij} / t \quad (3)$$

In Equation (3),  $SE_{IS}(i, j)$  is the information synergy,  $Tf_{ij}$  is the number of SIs, and  $t$  is the fixed time period. Process synergy promotes continuity between construction services and reduces uncertainty in engineering and construction. Its essence is to remove all types of redundant and non-value-added activities (NVAA) in neighboring construction services. The study uses the proportion of NVAA between AB construction services as the definition of process synergy, as shown in Equation (4).

$$SE_{PS}(i, j) = 1 - v_{ij} / (A_i, A_j) \quad (4)$$

In Equation (4),  $SE_{PS}(i, j)$  is the process synergy between AC service  $i$  and AC service  $j$ .  $v_{ij}$  is the NVAA, and  $A_i$  and  $A_j$  are the number of NVAA owned by AC service  $i$  and AC service  $j$ , respectively. Prefabricated plants and building sites are dispersed throughout large geographic areas, and ineffective communication between the assembly and construction services may result in longer delivery delays and more expensive delivery. The study is divided into four stages: the  $B_1$  (less than 1-2 hours), the  $B_2$  (2-4 hours), the  $B_3$  (4-6 hours), and the  $B_4$  (more than 6 hours). When the transportation time between AB construction enterprises  $i$  and  $j$  is  $B_k \in (B_1, B_2, B_3, B_4)$ . Equation (5) illustrates how the discrete value corresponding to  $B_k$  can be transferred to the distance relationship intensity  $SE_{Dis}(i, j)$ .

$$SE_{Dis}(i, j) = \begin{cases} 1.0, B(i, j) = B_1 \\ 0.6, B(i, j) = B_2 \\ 0.3, B(i, j) = B_3 \\ 0.0, B(i, j) = B_4 \end{cases} \quad (5)$$

In Equation (5),  $B(i, j)$  is the transportation time between AC services  $i$  and  $j$ . Higher value of  $SE_{Dis}(i, j)$  indicates better spatial synergy. In addition, resource synergy is considered as a key factor in the project portfolio. Equation (6) illustrates resource complementarity.

$$SE_{CR}(i, j) = 1 - C_{ij} / (H_i \cup H_j) \quad (6)$$

In Equation (6),  $SE_{CR}(i, j)$  is the resource synergy between AC services  $i$  and  $j$ . The number of hardware and software resource types that are the same between AC services  $i$  and  $j$  is denoted by  $C_{ij}$ . The software and hardware resource types that AC provides to  $i$  and  $j$  is denoted by  $H_i$  and  $H_j$ , respectively.

### 3.2 Improved IoT-based assembled construction system construction

To efficiently solve the problem of optimizing service quality in the SC environment for assembly construction, the project research has developed an optimal decision model for construction service combinations throughout the entire process, including design, production,

transportation, and site assembly. The model is based on the optimization problem of assembly construction service combination based on user demand, comprehensively considers the owner's constraints on the service combination, and takes the coordination effect and optimal service quality as the ultimate goal. Equation (7) provides the synergistic effect matrix construction formula, which may be used to graphically represent the differences in synergistic effect amongst AC services.

$$SEM = [S_{CS_i, CS_j}]_{n \times n}, \forall i, j = 1, \dots, n \quad (7)$$

In Equation (7),  $SEM$  denotes the synergy matrix, and  $S_{CS_i, CS_j}$  denotes the synergy between AC service  $i$  and  $j$ 's candidate service set  $(SE(i, j))$ . Without considering the existence of synergies between different service sets, the synergies between services within them are denoted by "0.00", and this matrix is symmetric  $(S_{CS_i, CS_j}, S_{CS_j, CS_i})$ .

The differences in technology, resources, and management of AB construction service providers have resulted in different degrees of service quality differences. The study selected five indexes of duration, cost, reliability, credibility and energy to evaluate the assembly construction service quality. By integrating the linear weights of the above attribute indices, the assessment results of the service quality level of assembly construction companies are obtained, as shown in Equation (8).

$$QoS = \varphi_1 QoS_d + \varphi_2 QoS_c + \varphi_3 QoS_{rel} + \varphi_4 QoS_{Re_p} + \varphi_5 QoS_e \quad (8)$$

In Equation (8),  $QoS$  denotes,  $QoS_d$ ,  $QoS_c$ ,  $QoS_{rel}$  and  $QoS_e$  denote five attribute indicators representative of AC service quality level, i.e., construction duration, cost, reliability, reputation and energy, respectively.  $\varphi_i$  represents the weighting coefficients of the five attribute indicators,  $\sum_{i=1}^5 \varphi_i = 1, 0 \leq \varphi_i \leq 1$ .

Fig. 3 shows the weighted collaborative network graph. Where nodes represent the quality of service provided by each service and edges represent the synergy between services. For AB services,  $S = (S_1, S_2, \dots, S_n)$  stands for the importance of service quality and  $L = (L_1, L_2, \dots, L_m)$  represents the set of edges for

synergy between sequential assembly construction services.  $\zeta = (\zeta_1, \zeta_2, \dots, \zeta_m)$  represents the strength of synergy between sequential assembly construction services. According to the specific delivery results of different construction phases, it is divided into  $m$  service granularity subtasks,  $T = (T_1, T_2, \dots, T_m)$ . For the  $m$  subtasks, the service set,  $CS = (CS_1, CS_2, \dots, CS_m)$ , is constructed as a weighted synergy network. The weighted synergy network diagram changes dynamically over time due to its work state and collaborative characteristics, which in turn affects the assembly construction service portfolio of the customized job.

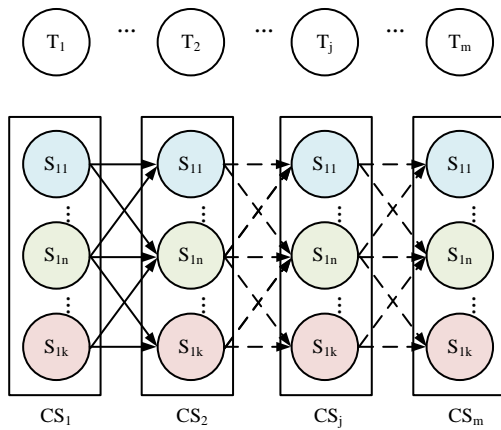

Figure 3: Schematic diagram of weighted collaboration network

The study aggregates the synergies between AC services from the design to the field assembly stage as the synergy objective function (OF)  $Z_1$ , as shown in Equation (9).

$$Z_1 = \sum_{i=1}^n \sum_{\substack{j=i \\ j \neq i}}^n se_{ij} x_i x_j \quad (9)$$

In Equation (9),  $n$  is the number of candidate services. The sum of the service quality of the AC's design, production, transportation, and on-site assembly processes serves as the AC's service quality objective  $Z_2$ , as specified in Equation (10).

$$Z_2 = \sum_{i=1}^n QoS_i x_i \quad (10)$$

Considering the differences in the preferences of different owners for synergies and service quality, the

study therefore transforms the bi-objective optimization problem into a single-objective optimization problem by applying a linear weighting method, and the total optimization OF  $Z$  is shown in Equation (11).

$$Z = \max(\alpha Z_1 + \beta Z_2) \quad (11)$$

When conducting the AC service combination scheme selection to achieve the optimization objective of maximizing the synergy effect-service quality, the condition constraints need to be set according to the actual construction of the AC project. The minimum required constraints for the synergy effect of AC service combination options are shown in Equation (12).

$$\begin{cases} Z_1 \geq \theta \\ x_i = x_j = 1 \\ se_{ij} \geq \phi \end{cases} \quad (12)$$

The minimum requirement constraints for the service quality of the AC service portfolio program are shown in Equation (13).

$$\begin{cases} Z_2 \geq \xi \\ x_i = 1 \\ QoS_i \geq \tau \end{cases} \quad (13)$$

The study proposes an assembly construction service combination collaboration-service quality optimization problem with a large set of candidate services for each subtask [19]. To address this problem, the study proposes a new idea based on genetic simulated annealing (GSA) algorithm, which is optimized so that it can obtain the optimal solution under the Metropolis criterion. The algorithm allows a small number of parents and offspring with high fitness to compete synergistically, thus accelerating the convergence rate while maintaining population diversity [20-21]. The Metropolis criteria, the fundamental principle of the simulated annealing algorithm, is first introduced to the genetic algorithm's selection, crossover, and mutation procedures as indicated by Equation (14).

$$P = \begin{cases} 1, & Fit_{new} < Fit_{cur} \\ e^{-(Fit_{new} - Fit_{cur})/T}, & Fit_{new} > Fit_{cur} \\ T = k \times T, & k \in [0, 1] \end{cases} \quad (14)$$

In Equation (14),  $Fit_{new}$  denotes the combined value of AC inter-service synergy and service quality.  $Fit_{cur}$  denotes the combined value of current AC inter-service synergy and service quality.  $T$  denotes the annealing temperature and  $k$  denotes the temperature decrease rate. The n-dimensional optimization problem is transformed into a one-dimensional optimization problem

as shown in Equation (15).

$$f(x_1, x_2, x_3, \dots, x_n) \rightarrow f(x_i) \quad (15)$$

The primary goal of the annealing algorithm is to guarantee superior genes while lowering the computational load, as genetic algorithms are prone to mutation. The new gene is approved if its adaption value is higher than it is prior to conversion. If not, the  $e^{-(Fit_{new}-Fit_{cur})/T}$  probability is used to determine whether to accept the gene. The mutation stops when the temperature drops below the set critical value (Fig. 4).

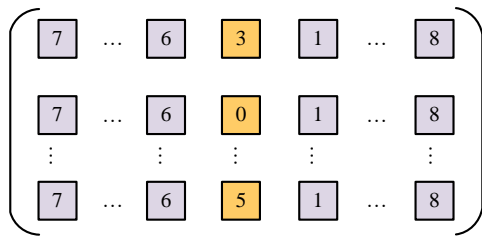

Figure 4: Process of gene mutation

## 4 Smart construction system performance analysis

The study evaluates the synergistic effect and service quality among AC services through an arithmetic simulation study. The study studies the scalability in terms of both task size and number of services in order to show the scalability and stability of the proposed SC system and GSA algorithm under large-scale service combination challenges.

### 4.1 Security analysis

For the simulation verification, 10 strong nodes and 10 full nodes are selected. The strong node stores the block header information of the blockchain ledger, can independently propose transaction on-chain requests, can become a verifier in the consensus organization, participate in assisting other transactions on the chain and verifying new blocks, but does not have the ability to independently generate new blocks. Full nodes store the complete blockchain ledger, have independent transaction and block verification functions, and can act as a verifier in a consensus organization. They are the only type of node that can generate new blocks. The node reputation mechanism generates behavior scores for the nodes to be evaluated based on normative criteria. If more than 70% of the scores are negative, the environment is considered untrusted, while the remaining scores indicate a trusted environment.

Building IoT devices act as collectors and

forwarders of sensed data, aggregating the data to a centralized system for storage and processing, and a secure, trustworthy and efficient building IoT architecture is the foundation of everything. Twenty nodes exhibiting pertinent behaviors are put up for the investigation, and Fig. 5 displays the outcomes. The network evaluation in an unreliable environment is depicted in Fig. 5(a). In this network, most of the nodes are untrustworthy or malicious, so the higher they rate the evaluated nodes, the more likely they are to be potentially dangerous nodes, which leads to more negative feedback. In this Fig., the untrustworthy environment brings negative feedback to 20 evaluated nodes. In addition, when the assessed node has a higher degree of association and relevance to the network, then the more negative ratings it receives. Fig. 5 (b) shows the network evaluation in a trusted environment, in which the network evaluation scores are positive for all 20 evaluated nodes. In this figure, the higher the correlation between the user and the trust, trustworthiness, and trustworthiness in a more trustworthy network environment, the better the evaluation results obtained. However, when there is a correlation between the evaluated node and the untrusted non-trusted node, there is a greater negative impact, and in order to obtain more trust values, the correlation with the untrusted node has to be reduced to isolate the untrusted node.

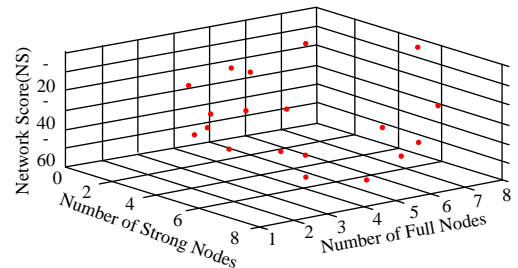

(a) Untrusted environment

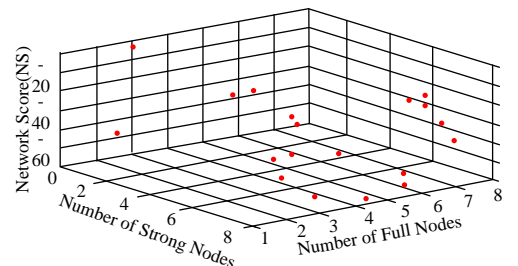

(b) Trusted environment

Figure 5: Network evaluation feedback in different peer-to-peer network environments

The study conducted 20 rounds of testing for each of the four scenarios to obtain the range and trend of the behavioral scores of the nodes in different scenarios with respect to the overall. Fig. 6(a) shows trusted nodes in untrustworthy environment. The behavior of the node is

not affected by the external environment and only gets feedback through its own various behaviors. Figure 6(b) displays the trusted node within a trusted environment. The node and its associated nodes behave in a trustworthy manner, resulting in positive feedback and an increase in the overall score index of the node relative to the individual's behavioral score. It is proved that the various behaviors of the nodes satisfy the requirements of the reputation mechanism, thus gaining more trust. Fig. 6(c) shows the untrusted node in an untrusted environment. When an untrusted node is in an untrusted environment, the node is more likely to collude with other malicious nodes with a higher degree of maliciousness. According to Fig. 6(d), untrusted nodes in trusted environments are more likely to fail due to poor performance rather than malicious intent when they are located in a trusted network environment that is more relevant to the honest node.

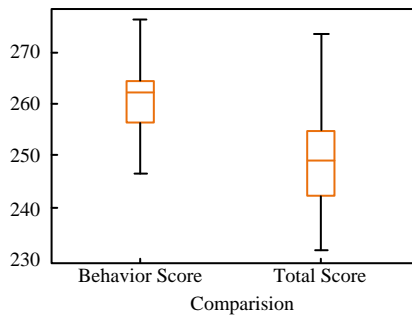

(a) The trusted node is in an untrusted environment



(b) A trusted node is in a trusted environment

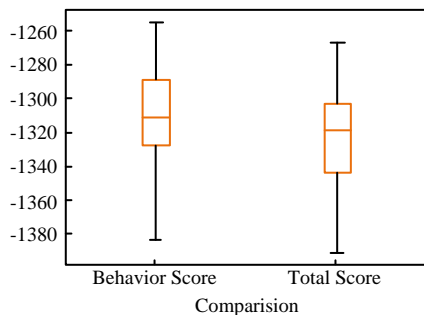

(c) An untrusted node in an untrusted environment

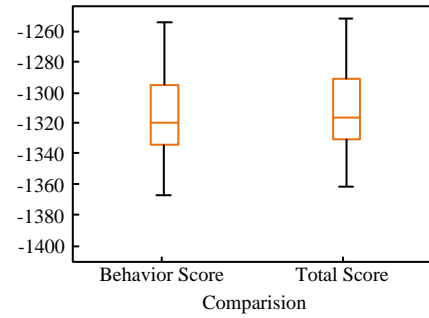

(d) The untrusted node is in a trusted environment

Figure 6: Analyzes the potential trend of nodes based on network evaluation

### 4.2 Parameter analysis

A sensitivity analysis of the population size, crossover probability, and mutation probability in the GA is performed. The algorithm is limited to 200 iterations, and the experiments corresponding to each parameter are averaged 5 times for analysis. Fig. 7 displays the sensitivity experiment results. Fig. 7(a) shows that the objective function value is relatively high when the population is less than 80. This is because a smaller population leads to less computation and a smaller search range of the solution space, making it difficult to find a convergent solution. Similarly, Fig. 7(b) demonstrates that the objective function value is larger when the crossover probability is less than 0.8. The low crossover probability causes the offspring to retain more parental gene fragments, which hinders the generation of new solutions and limits the search range. Fig. 7(c) shows that when the variation probability exceeds 0.05, the objective function tends to fluctuate and decrease, indicating a decrease in solution effectiveness. In the range of 0.01 to 0.05, the objective function remains relatively stable with minor changes.



(a) Population size sensitivity



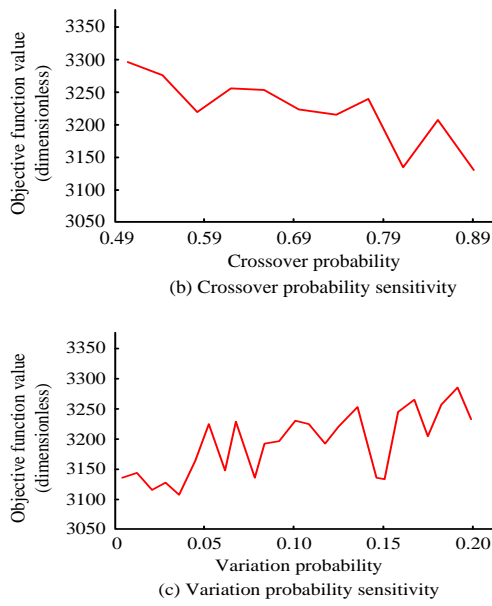

Figure 7: Results of sensitivity experiments

The crossover probability (CP) and variance probability (VP) of the GSA algorithm are subjected to sensitivity analysis because the algorithm's parameters have an impact on the algorithm's solution findings. First, 0.3, 0.5, 0.7, and 0.9 are the four distinct crossover probabilities that are set. The outcomes are displayed in Fig. 8(a). It is evident that 0.7 is the ideal CP. The sensitivity analysis of the variation probability is then carried out when the CP is adjusted to 0.7, and the outcomes are displayed in Fig. 8(b). It should be mentioned that the algorithm performs best with the VP set to 0.3.

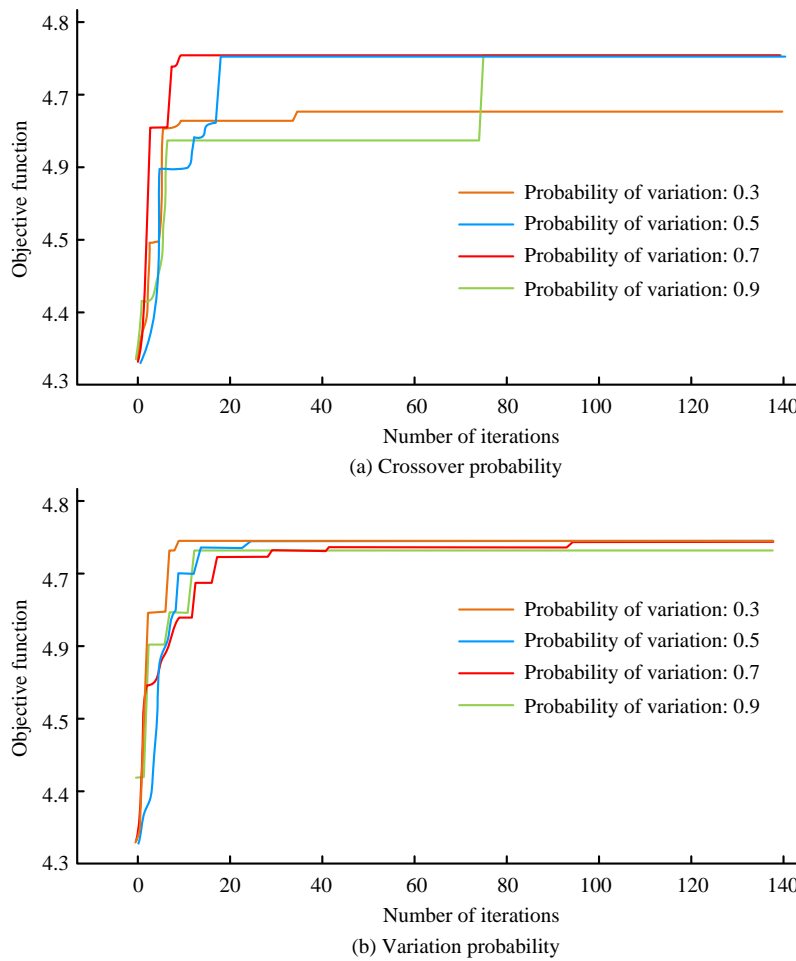

Figure 8: Sensitivity analysis of GSA algorithm

The search ability of the GSA algorithm becomes stronger as the population size increases, but the optimization time also increases. For less complex optimization problems, the initial population size set by the algorithm is usually greater than 50. It is recommended to set a high initial simulated annealing temperature and slow down the simulated annealing process to improve the probability of finding a global

optimal solution. Assume the following values:  $VP = 0.3$ ,  $CP = 0.7$ , starting temperature = 100, cooling factor = 0.98, annealing interference count = 10, and annealing step size = 0.02. The method's average and optimal fitness (OFit) values are displayed in Fig. 9. After roughly 13 iterations, the approach in Fig. 8 achieves the ideal fitness of 4.81.

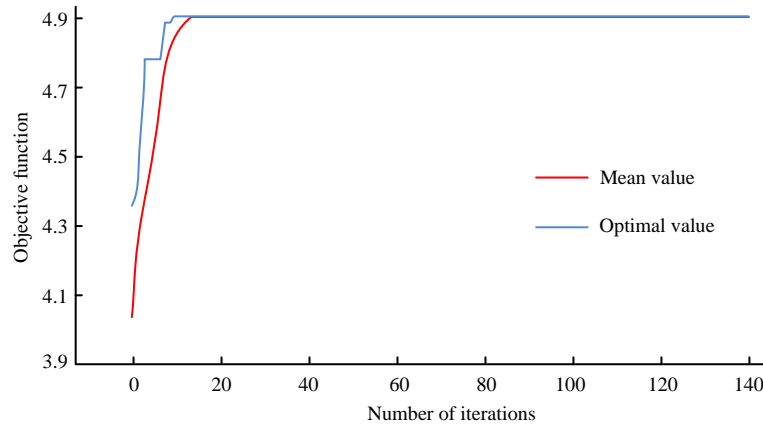

Figure 9: Trends of optimal fitness values and average fitness values

The study aims to confirm the efficacy of the GSA algorithm by adjusting the parameters of the PSO algorithms, SA and GA to align with the enhanced algorithm. These algorithms are then utilized to solve the built AC service portfolio synergy effect-service quality optimization model, yielding the OF, synergy effect, and service quality values of various intelligent optimization algorithms, as illustrated in Fig. 10(a). When comparing the GSA algorithm to the PSO algorithms, SA and GA, it exhibits the smallest error in the synergistic effect, indicating a high level of reliability when compared to the unimproved previous algorithm. In Fig. 10 (b) and (c), the GSA algorithm has the smallest error in the quality of service and OF value. The GSA algorithm's overall quality of service value is 4.52, which is marginally less than GA's value of 4.54. Nonetheless, the GSA algorithm's OF value of 4.81 and synergy value of 5.26, which are higher than those of the PSO algorithms, SA and GA, show that the GSA algorithm is dependable and trustworthy.

### 4.3 Comparative analysis of optimization results

The study repeats the GSA, PSO algorithms, SA and GA 20 times in order to eliminate experimental chance. The performance of the algorithms is then verified in terms of the number of converged generations and the time it takes the algorithms to reach the converged state. The results are displayed in Fig. 11. The GSA algorithm in Fig. 11(a) converges more quickly than the PSO algorithms, SA and GA combined. The GSA approach requires a much fewer number of iterations than the PSO algorithms, SA and GA to reach the converged state, as shown in Fig. 11(b). The method performs better overall than the PSO algorithms, SA and GA, as demonstrated by the results above.

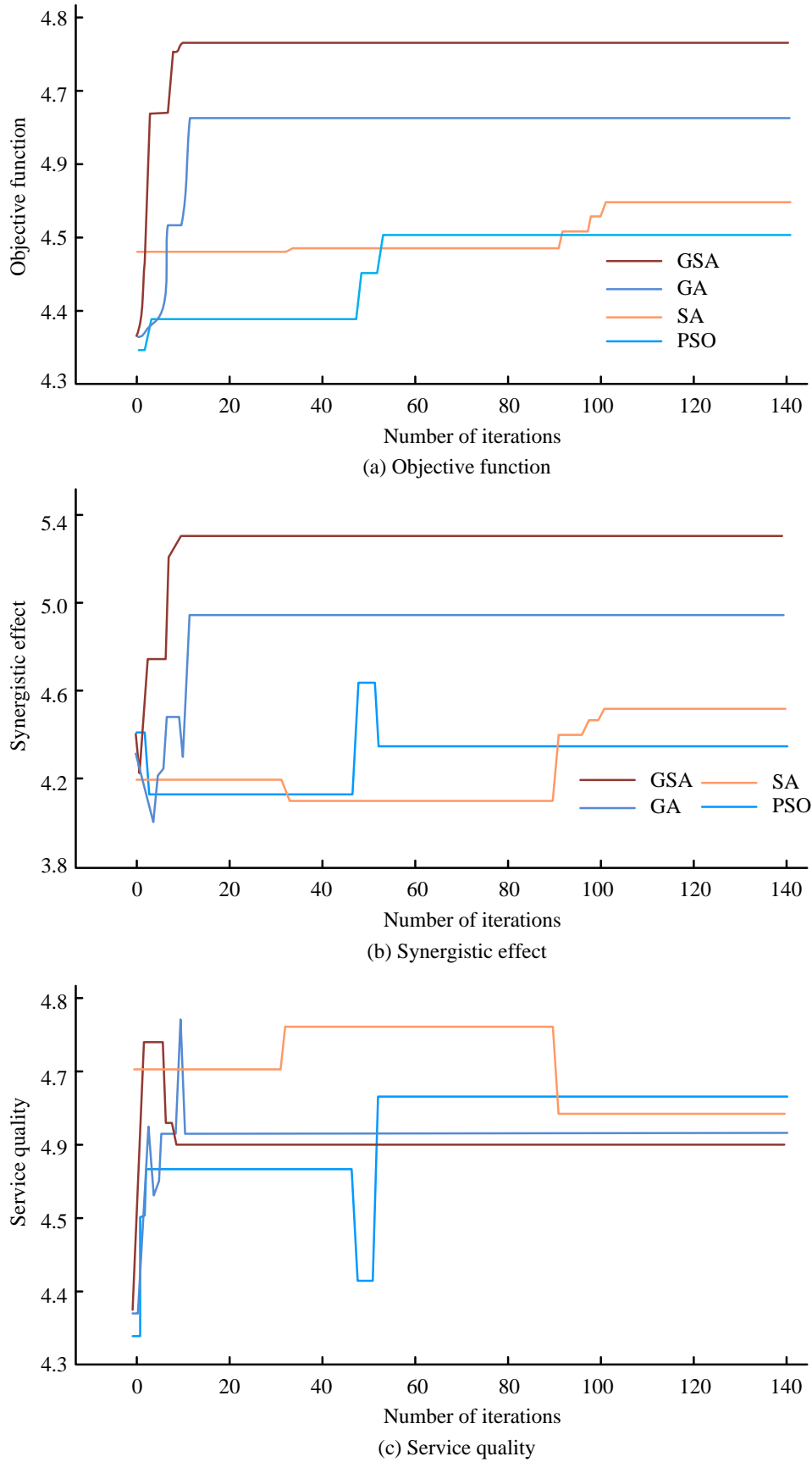

Figure 10: Comparison of options

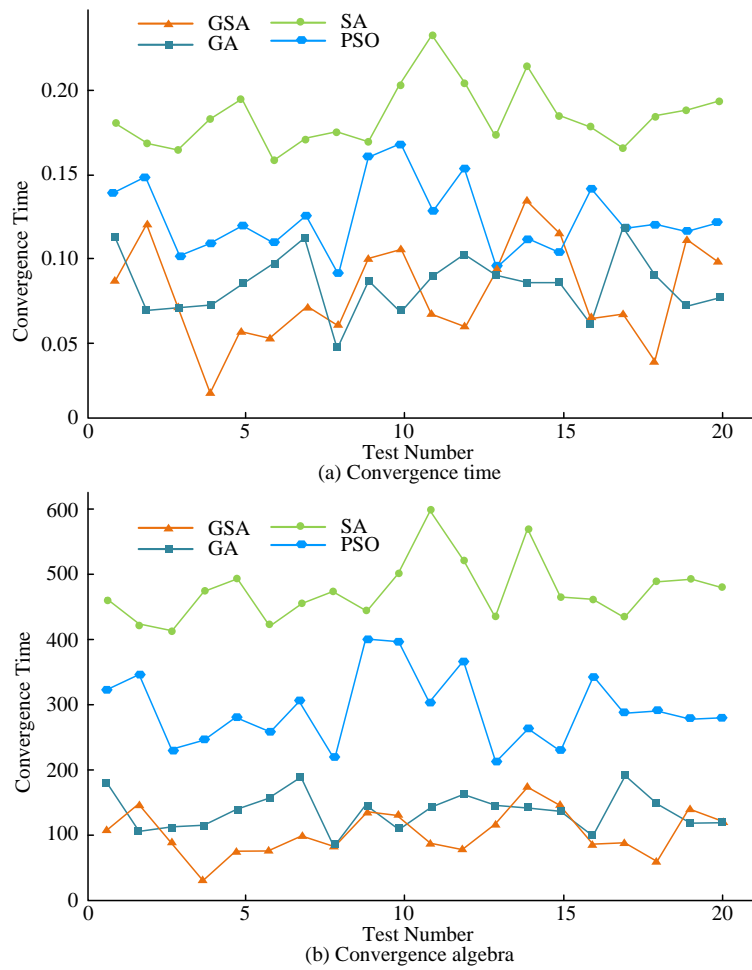

Figure 11: Comparison of algorithm convergence performance

By validating the method's stability and scalability, the study confirms the efficacy of the suggested methodology. Without changing the subtasks, four types of combined assembly construction services such as  $6 \times 20$ ,  $6 \times 40$ ,  $6 \times 100$  and  $6 \times 100$  are set. The optimization problems of the above four types are investigated using three algorithms, GSA, GA, and SA. In Table 2, the OF

values of the GSA algorithm are basically all greater than those of the GA and SA algorithms at the same problem size. As the services increases, the probability of high-quality AB services in the set of candidate services increases significantly, making the OF of the optimization problem increase gradually

Table 2: Algorithm performance comparison under different service quantity

Problem scale		$6 \times 20$	$6 \times 40$	$6 \times 60$	$6 \times 100$
GSA	Optimal solution	5.33	27.03	16.21	25.44
	Synergistic effect	7.85	63.21	35.42	59.67
	Service quality	3.52	2.97	3.08	3.03
GA	Optimal solution	5.23	26.54	21.87	24.98
	Synergistic effect	8.16	61.52	48.37	57.23
	Service quality	4.81	14.07	10.58	22.65
SA	Optimal solution	4.83	14.52	10.48	22.68
	Synergistic effect	5.41	30.24	21.57	51.87
	Service quality	3.67	2.79	3.31	3.22

By comparing the OF values of the three algorithms GSA, GA and SA under different number of services, the comparison results shown in Table 3 are obtained. In

Table 3, the OF of GSA algorithm almost always exceeds the OF values of the other three algorithms at the same scale. Compared with GA and SA algorithms, this

algorithm has better performance. As the AC subtasks increases simultaneously with the AC services, the OF value of the AC service combination synergy effect-service quality optimization model keeps improving.

Table: 3 Performance comparison of algorithms under different problem sizes

Problem scale		4×5	5×10	10×15	15×20	20×25
GSA	Optimal solution	2.45	4.32	14.15	15.16	23.35
	Synergistic effect	2.26	7.62	28.41	26.87	43.51
	Service quality	2.51	2.26	4.79	7.18	9.46
GA	Optimal solution	2.48	4.13	8.47	14.08	28.56
	Synergistic effect	2.53	5.67	12.48	23.17	55.64
	Service quality	2.36	3.04	5.14	7.95	10.63
SA	Optimal solution	2.48	4.36	9.94	10.85	16.54
	Synergistic effect	2.55	6.78	17.36	13.48	25.61
	Service quality	2.48	2.61	4.69	8.06	10.97

The study uses the think tank building project as an example to conduct an analysis. The results are presented in Table 4. The total investment for the project was 535 million yuan, making it an application demonstration project for an intelligent construction visualization platform. Between January 2022 and January 2023, the platform implemented tower crane monitoring and warning 355 times, resulting in a labor cost savings of 355,000 yuan. Additionally, lift warning was activated 65 times, saving 65,000 yuan in labor costs. The spray linkage was opened 318 times, resulting in a savings of 159,000 yuan by reducing management input by 500 yuan each time. Based on a 1% probability of flooding accidents, water level monitoring and warning occurred 3,612 times, resulting in a cost savings of 361,200 yuan,

with each treatment costing 10,000 yuan. The system automatically issued warnings over 3,000 times for not wearing helmets or reflective clothing, or engaging in other unsafe behaviors. Each warning costs 50,000 yuan to process, and the risk probability is calculated at 0.1%. This resulted in a savings of 150,000 yuan. Additionally, effective schedule management reduced the construction period by 5 days, resulting in a total savings of 300,000 yuan (calculated at 60,000 yuan per day). Finally, water and electricity management reduced the monthly hydropower cost by 800 yuan, resulting in a total savings of 0.72 million yuan. Compared to the traditional construction scheme, the project saved a total of 1.3974 million yuan.

Table 4: Comparison of economic benefits with traditional construction schemes

Item	Frequency	Cost savings compared with traditional construction scheme (ten thousand yuan)
Tower crane monitoring and warning	355	35.5
Elevator warning	65	6.5
Spray linkage opens	318	15.9
Water level monitoring and warning	3612	36.12
Automatic warning does not wear helmet, reflective clothing and other behavior	3521	15
Shorten the construction period	/	30
Water and electricity management	/	0.72
Total	/	139.74

## 5 Discussion

During the process of constructing a network, it is important to consider information ethics. The most significant public concern regarding smart building systems is personal privacy. However, smart technology, particularly in buildings, does not necessarily infringe on privacy. Although people desire smarter buildings, they may not consent to the collection of information about

their activities, which can create tension between users and construction companies [22]. However, users have no better option if they want a good experience, and their personal data may still be identified even if they do not consent to its collection by businesses or third parties. Ethical debates about the protection of personal information are common. General building management departments should position themselves and assume their ethical responsibility for service.

This study examines the updating mechanism of a consensus-based organization. It proposes a consensus organization model based on the credibility of validators and the reliability of consensus. This study analyzes the types of nodes and behaviors in the blockchain network under the construction networking scenario. It evaluates the associated behaviors in the peer-to-peer network by combining the success rate, enthusiasm, and real-time performance of various node behaviors. According to Zhang Y et al., degradation had little impact on the scores obtained by nodes through individual behavior performance. Therefore, nodes were still trusted by the system despite accounting for a relatively small proportion. This finding is consistent with the given study [23]. A decrease in value may suggest that a reliable node is being intentionally evaluated negatively by an unreliable node in an effort to disrupt the system's standard evaluation of the node. As a result, the system will concentrate on monitoring the unreliable node that is conducting the evaluation. Additionally, reliable nodes are more frequently linked to malicious nodes, so it is important to increase monitoring of these nodes in case they become potential malicious nodes that engage in harmful behavior in the future. When a node's overall score trend increases slightly based on positive feedback network evaluation scores, it indicates that the node's risk is not high. However, the reputation mechanism will still mark the node's behavior as having a high failure rate through the individual behavior score.

This study presents a platform that integrates project management and IoT technology to manage project schedule, quality, safety, cost, design, and technology. The platform utilizes reliability as the basis for selecting validators in the consensus organization. As a result, an improved IoT prefabricated building intelligent construction system with distributed security and high efficiency is achieved. By optimizing the parameters of the GSA algorithm, higher convergence and stability are achieved. Finally, through actual case verification, the system saved a total cost of 1.3974 million yuan for the project, which is better than the schemes proposed by Wang J et al and Cai H et al [24-25]. This optimization realizes the standardization, safety, intelligence, information, and visual development of building construction, and provides a reference for the intelligent construction of other projects.

## 6 Conclusion

The study develops an IoT-based intelligent construction system for AB by investigating the current development process, management status quo, and construction characteristics of AB. The study also conducts a comprehensive review of domestic and international literature to address the current defects of the SC system of AB and meet the demands of stakeholders. Advanced information technology is utilized to achieve this goal. The results indicated that the SC system based on AB

with improved IoT combines both efficiency and security. The GSA algorithm was optimal when the CP was 0.7 and the VP was 0.3. After around thirteen cycles, the OFit was 4.81. The average fitness achieved the convergence state and equaled the OFit after roughly 17 iterations. The OF values of the GSA algorithm were basically all greater than those of the GA and the SA algorithm for the same problem size and number of services. This study proposes a method for optimizing service mix selection in sequential prefabricated construction processes. The method aims to integrate industry standards to standardize operations, behavior, and data format, promoting system standardization and improving efficiency.

## References

- [1] Z. Xu, G. Hu, M. Jia, and L. Dong, "Potential transmission choice for Internet of Things (IoT): Wireless and batteryless communications and open problems," *China Communications*, vol. 18, no. 2, pp. 241-249, 2021. <https://doi.org/10.23919/JCC.2021.02.016>
- [2] A. M. Usman, and M. K. Abdullah, "An assessment of building energy consumption characteristics using analytical energy and carbon footprint assessment model," *Green and Low-Carbon Economy*, vol. 1, no. 1, pp. 28-40, 2023. <https://doi.org/10.47852/bonviewGLCE3202545>
- [3] X. M. Liu, T. P. Singh, R. K. Gupta, and E. M. Onyema, "Chaotic Association Feature Extraction of Big Data Clustering Based on the Internet of Things," *Informatica*, vol. 46, no. 3, pp. 333-342, 2022. DOI:10.31449/inf.v46i3.3943.
- [4] K. Liu, Y. Sun, and D. Yang, "The administrative center or economic center: Which dominates the regional green development pattern. A case study of Shandong peninsula urban agglomeration, China," *Green and Low-Carbon Economy*, vol. 1, no. 3, pp. 110-120, 2023. <https://doi.org/10.47852/bonviewGLCE3202955>
- [5] H. N. Bhor, and M. Kalla, "TRUST-based features for detecting the intruders in the Internet of Things network using deep learning," *Computational Intelligence*, vol. 38, no. 2, pp. 438-462, 2022. <https://doi.org/10.1111/coin.12473>
- [6] X. Yan, H. Zhang, and W. Zhang, "Intelligent monitoring and evaluation for the prefabricated construction schedule," *Computer-aided Civil and Infrastructure Engineering*, vol. 38, no. 3, pp. 391-407, 2023. <https://doi.org/10.1111/mice.12838>
- [7] P. Ouyang, X. Ouyang, Y. Z. Peng, and A. Y. Pan, "Information visualization method for intelligent construction of prefabricated buildings based on P-ISOMAP algorithm," *International Journal of Emerging Electric Power Systems*, vol. 24, no. 1, pp. 73-89, 2022. <https://doi.org/10.1515/ijeeps-2022-0118>

- [8] Z. Li, and Y. Huang, "Antiseismic method of prestressed fabricated building structure under intelligent big data," *Mathematical Problems in Engineering*, vol. 21, no. 46, pp. 770-782, 2021. <https://doi.org/10.1155/2021/9834770>
- [9] H. Ding, M. Li, R. Y. Zhong, and G. Q. Huang, "Multistage self-adaptive decision-making mechanism for prefabricated building modules with IoT-enabled graduation manufacturing system," *Automation in Construction*, vol. 148, no. 4, pp. 104755.1-104755.18, 2023. <https://doi.org/10.1016/j.autcon.2023.104755>
- [10] X. Wang, Q. Du, C. Lu, and J. Li, "Exploration in carbon emission reduction effect of low-carbon practices in prefabricated building supply chain," *Journal of Cleaner Production*, vol. 368, no. 25, pp. 1-13, 2022. <https://doi.org/10.1016/j.jclepro.2022.133153>
- [11] Y. Wu, Y. Wu, J. M. Guerrero, J. C. Vasquez, and Y. Guan, "IoT-enabled microgrid for intelligent energy-aware buildings: A novel hierarchical self-consumption scheme with renewable," *Electronics*, vol. 9, no. 4, pp. 550-563, 2020. <https://doi.org/10.3390/electronics9040550>
- [12] J. C. Babu, M. S. Kumar, P. Jayagopal, V. E. Sathishkumar, S. Rajendran, S. Kumar, A. Karthick, and A. M. Mahseena, "IoT-Based intelligent system for internal crack detection in building blocks," *Journal of Nanomaterials*, vol. 22, no. 6, pp. 3947760.1-3947760.8, 2022. <https://doi.org/10.1155/2022/3947760>
- [13] S. Xi, C. Zhang, Z. Cai, and Y. Xu, "Cost control and project cost analysis of intelligent building under Internet of Things," *Mobile Information Systems*, vol. 6, no. 7, pp. 7040-7052, 2021. <https://doi.org/10.1155/2021/8217040>
- [14] T. H. Lin, Y. H. Huang, and A. Putranto, "Intelligent question and answer system for building information modeling and artificial intelligence of things based on the bidirectional encoder representations from transformers model," *Automation in Construction*, vol. 142, no. 8, pp. 483-495, 2022. <https://doi.org/10.1016/j.autcon.2022.104483>
- [15] R. Casado-Vara, A. Martin-Del Rey, S. Affes, J. Prieto, and J. M. Corchado, "IoT network slicing on virtual layers of homogeneous data for improved algorithm operation in smart buildings," *Future Generation Computer Systems*, vol. 102, no. 6, pp. 965-977, 2020. <https://doi.org/10.1016/j.future.2019.09.042>
- [16] H. Cao, Y. Wu, Y. Bao, X. Feng, S. Wan, and C. Qian, "UTrans-Net: A model for short-term precipitation prediction," *Artificial Intelligence and Applications*, vol. 1, no. 2, pp. 106-113, 2023. <https://doi.org/10.47852/bonviewAIA2202337>
- [17] A. Ly, and Z. El-Sayegh, "Tire wear and pollutants: An overview of research," *Archives of Advanced Engineering Science*, vol. 1, no. 1, pp. 2-10, 2023. <https://doi.org/10.47852/bonviewAAES32021329>
- [18] S. Garai, R. K. Paul, and M. Kumar, "Intra-annual national statistical accounts based on machine learning algorithm," *Journal of Data Science and Intelligent Systems*, vol. 2, no. 2, pp. 12-15, 2023. <https://doi.org/10.47852/bonviewJDSIS3202870>
- [19] Y. Ren, W. Liu, A. Liu, T. Wang, and A. Li, "A privacy-protected intelligent crowdsourcing application of IoT based on the reinforcement learning," *Future Generation Computer Systems*, vol. 127, pp. 56-69, 2022. <https://doi.org/10.1016/j.future.2021.09.003>
- [20] Z. W. Zhang, "Quality management and safety evaluation for prefabricated buildings," *International Journal of Performability Engineering*, vol. 16, no. 5, pp. 1060-1030, 2020. <https://doi.org/10.23940/ijpe.20.05.p15.811820>
- [21] X. Yan, and H. Zhang, "Computer vision-based disruption management for prefabricated building construction schedule," *Journal of Computing in Civil Engineering*, vol. 35, no. 6, pp. 1027-1046, 2021. [https://doi.org/10.1061/\(ASCE\)CP.1943-5487.0000990](https://doi.org/10.1061/(ASCE)CP.1943-5487.0000990)
- [22] Z. You, and L. Feng, "Integration of industry 4.0 related technologies in construction industry: A framework of cyber-physical system," *IEEE Access*, vol. 8, no. 7, pp. 122908-122922, 2020. <https://doi.org/10.1109/ACCESS.2020.3007206>
- [23] Y. Zhang, and H. Hu, "Data envelopment analysis-based efficiency measurement of engineering change controlling for infrastructure construction under integrated project delivery mode," *IET Intelligent Transport Systems*, vol. 14, no. 11, pp. 1433-1439, 2020. <https://doi.org/10.1049/iet-its.2019.0779>
- [24] J. Wang, Y. Mohamed, S. H. Han, X. Li, and M. Al-Hussein, "3D ergonomics-based motion-level productivity analysis for intelligent manufacturing in industrialized construction," *Canadian Journal of Civil Engineering*, vol. 50, no. 3, pp. 197-209, 2023. <https://doi.org/10.1139/cjce-2022-0090>
- [25] H. Cai, Y. Chen, K. Elbaz, and C. Zhang, "Intelligent building system for 3D construction of complex brick models," *IEEE Access*, vol. 8, no. 12, pp. 182506-182516, 2020. <https://doi.org/10.1109/ACCESS.2020.3027807>

